

Vent Valve Assembly Model 5009007

IMPORTANT 重要提示

Maximum hydraulic oil temperatura:100 °C

液压油最高温度:100 °C

-Maxmum hydraulic pressure:103bar 最大液压压力103bar

-Maxmum lubricant pressure:262bar 最大润滑压力262bar

-Hydraulic pressure required to seal valve with 241bar lubricant pressure :21bar
用241bar 润滑油密封阀门所需的液压压力:21bar

-Recommended fluid:lubricant NLGI grade 1 or lighter

推荐润滑液:NLGI 1级或更轻的润滑剂

-Dimensions 尺寸:159x57mm

Warning 警告:

To prevent over pressurization,a pressure relief valve 11 must be used in conjunction with all vent valve.为了防止过压, 必须在所有排气阀的同时使用一个压力减压阀11。

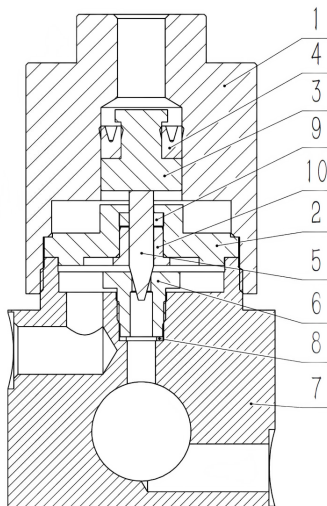
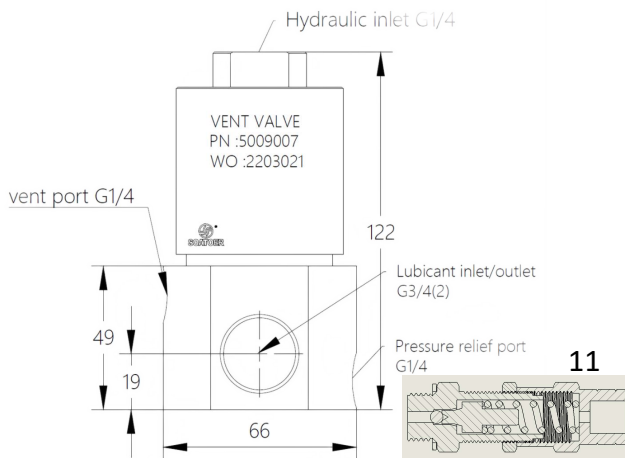

Item	Description	Part. No.	Q.ty
1	Hydraulic Cylinder	5009171	1
2	Packing retainer	5009162	1
3	Piston	5009173	1
4	U-cup	5082114	1
5	Needle	5009164	
6	Valve seat	5009165	1
7	Valve body	5009166	1
8	Check seat gasket	5009167	1
9	Needle seal	6020113	1
10	Needle seat	5009168	1
11	Pressure relief valve	5009001	1

Distributor Info: