

Vent Valve Assembly 泄压阀型号 Model 5009006

- Maximum air pressure:8 bar,最大空气压力8 bar
- Maximum lubricant pressure:262bar,最大润滑剂压力262bar
- Air pressure required to seal valve with 241 bar lubricant pressure :4 bar

润滑压力241bar密封阀门所需液压:4 bar

- Recommended fluid:lubricant NLGI grade 1 or lighter
- 推荐液体:NLGI 1级润滑油或更轻的

-Dimensions尺寸:159x57mm

Warning提示:

To prevent over pressurization,a pressure relief valve 11 must be used in conjunction with all vent valve.

为了防止过度增压，必须在所有放气阀的配合下使用安全阀11。

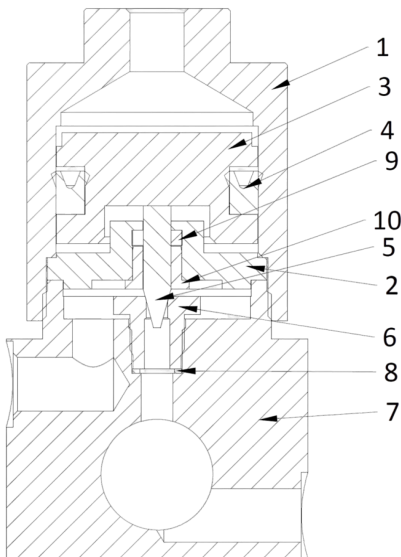
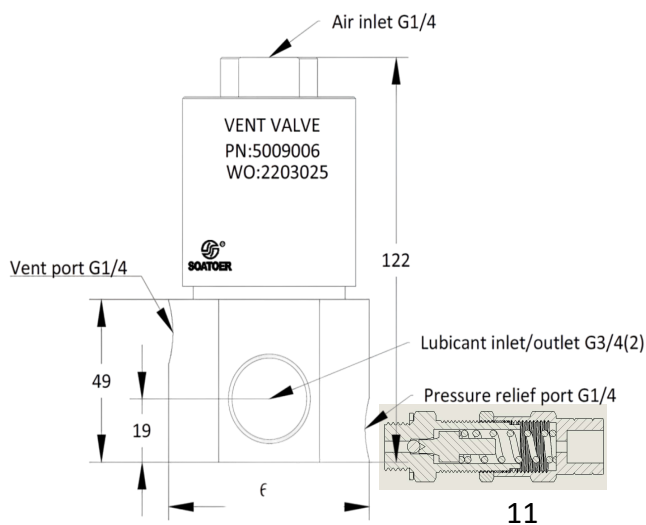

Item	Description 描述	Part. No.	Q.ty
1	Pneumatic Cylinder	5009161	1
2	Packing retainer	5009162	1
3	Piston	5009163	1
4	U-cup	5082113	1
5	Needle	5009164	1
6	Valve seat	5009165	1
7	Valve body	5009166	1
8	Check seat gasket	5009167	1
9	Needle seal	6020113	1
10	Needle seat	5009168	1
11	Pressure relief valve	5009001	1