

CHARACTERISTICS 特性

- **SINGLE LINE PNEUMATIC PUMP;** 单作用气动泵
- **PUMP:39ml PER CYCLE;** 每冲程39ml
- **RATIO压缩比: 31:1;**
- **RESERVOIR CAPACITY 1-2-5 litres**油箱容量1-2-5升
- **MINIMAL LEVEL SENSOR AS STANDARD;** 标准配备低液位
- **AIR SUPPLY PRESSURE: (3 - 8 bar);** 供气压力:(3 - 8bar);
- **OIL PUMP:32 -1000 cSt.** 油泵:32 - 1000cst。

A SIMPLE AND VERSATILE OIL PUMP IDEAL FOR SMALL AND MEDIUM LUBRICATION SYSTEMS 一个简单和通用的油泵理想的中小型润滑系统

POG-oil is a single acting pneumatic pump, generally used in lubrication systems with XL-32,XL-33,XL-42,XL-43,XL-44 single line progressive systems.

POG-oil是一种单作用气动泵，一般用于润滑系统与XL-32,XL-33,XL-42,XL-43,XL-44单线系统。

POG-oil is available with a 1-2-5-litre reservoir. POG-oil可用于1-2-5升的油箱

The transparent reservoir allows you to see the remaining quantity of oil clearly and a minimum level sensor allows remote alarm signals to be sent to the monitoring equipment.

透明的储层可以让你清楚地看到剩余的油量，最小液位传感器可以远程报警信号发送到监控设备。

Additionally, the reservoir lid can be installed with a High level or a Soatoer continual level sensing device.

此外，储液罐的盖子可以安装一个高液位或Soatoer连续液位传感装置。

The pump is fitted with a filling filter that guarantees the intake of clean lubricant into the reservoir. 该泵配有一个灌装过滤器，以保证清洁的润滑油进入油箱。

High Reliability is guaranteed by the use of hardened steel in the construction in all the pumping element components and the pump piston is manufactured in ground-hardened steel.

高可靠性的保证是在所有泵送元件的结构中使用淬硬钢，泵活塞是由地面淬硬钢制造的。

POG-oil is the simple and effective solution for the lubrication of machinery with small and medium systems. It is ideal for use on machinery where compressed air is available.

POG-oil 是中小型系统机械润滑简单有效的解决方案。它适用于有压缩空气的机械设备。

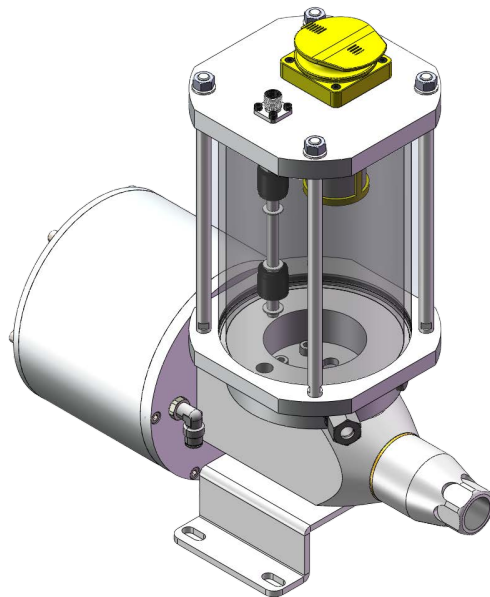

TECHNICAL INFORMATION 技术参数

TECHNICAL CHARACTERISTICS 技术特性

Pumping system 泵的类型	Single acting pneumatic piston 单作用气动活塞泵
Air pressure 空气压力	3÷8 bar
Compressed air inlet 空气压力进口	G 1/4 UNI - ISO 228/1
Lubricant outlet 润滑剂输出螺纹	G 1/4 UNI - ISO 228/1
Compression ratio 压缩比	31:1
Flow rate 排量	39 cm ³ / stroke
Permitted lubricants 润滑剂*	32-1000 cSt oil
Piston total stroke 活塞总行程	82mm
Piston working stroke 活塞工作行程	80 mm
Minimum level contact 低液位连接	V max.= 220 V AC /1AMA/P.MAX 50 W
Working temperature 工作温度	+5 ÷ +50°C
Storage temperature 储存温度	+5 ÷ +50°C
Relative humidity without operating 湿度	90%
Sound pressure level 声压计	< 70 dB(A)
Net weight 净重	15 Kg

APPLICATIONS 应用

- **LUBRICATION IN VEHICLES AND MOBILE PLANTS;** 车辆润滑和移动设备;
- **MACHINE TOOLS: SUCH AS MACHINES FOR WORKING SHEET METAL OR WOOD;** 机床: 如加工钣金或木材的机器;
- **BENDING MACHINES;** 折弯机
- **INJECTION PRESSES FOR PLASTICS.** 注塑冲压塑料。

DIMENSIONS 外形尺寸

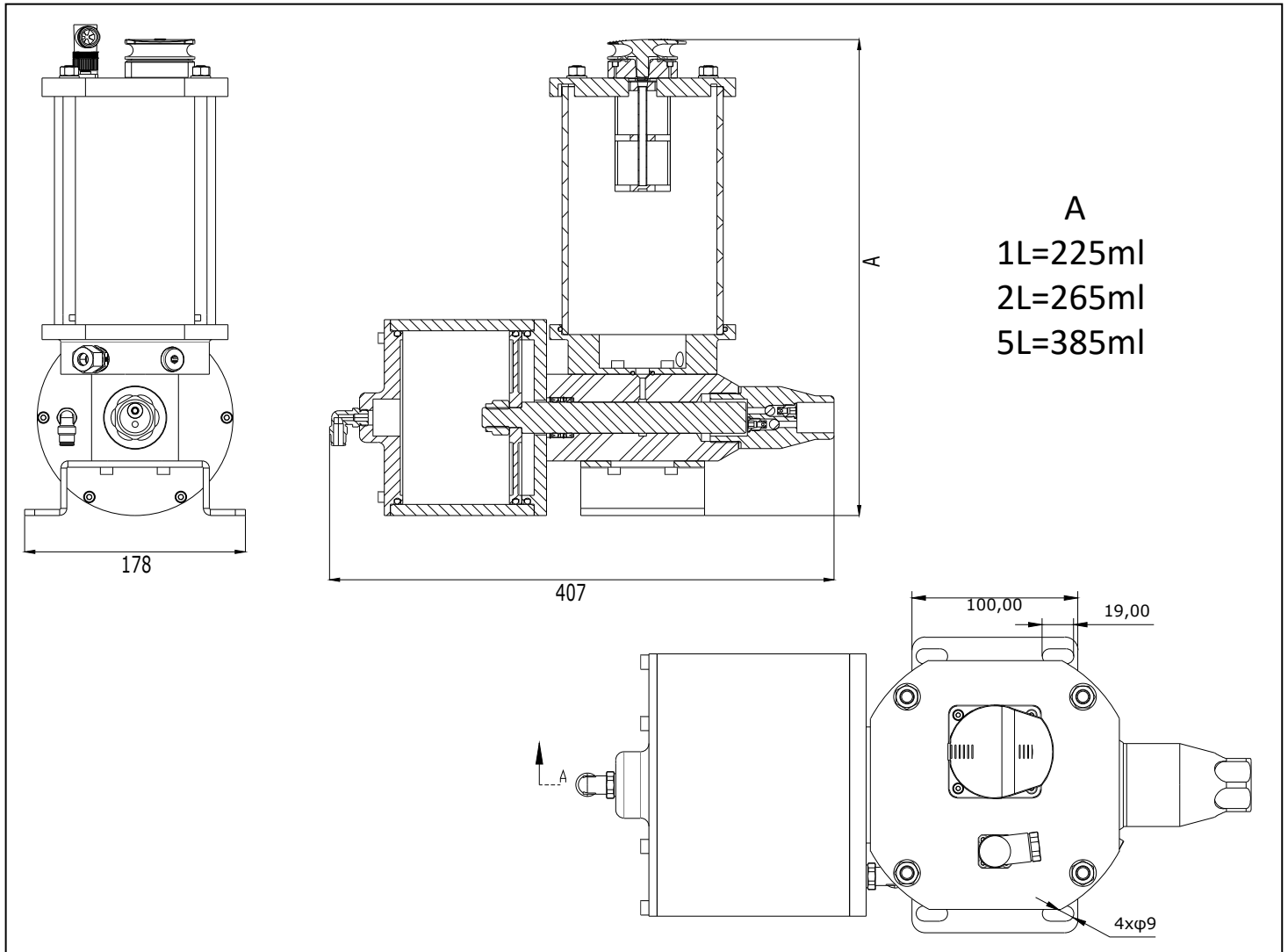

ORDER INFORMATION 订购信息

DESCRIPTION 描述	P. No
31:1 OIL PUMP WITH NC LEVEL-31:1带常闭低液位的油泵	1001022
31:1 OIL PUMP WITH NO LEVEL-31:1带常开低液位的油泵	1001021

SPARE PARTS 备件

DESCRIPTION 备件	P. No
1-2-5-litre perforated reservoir,1-2-5升油箱	1L-1001088; 2L-1001089; 5L-1001085
Support plate 安装板	1001022
Pump unit 泵	1001071
Minimum level sensor 常开低液位	5008040
Minimum level sensor 常闭低液位	5008045
Refilling filter 加油过滤器	1008029